

# S5560 55A SCRs

## FEATURES

- High thermal cycling performance
- High voltage capacity
- Very high current surge capability

## APPLICATIONS

- Line rectifying 50/60 Hz
- Softstart AC motor control
- DC Motor control
- Power converter
- AC power control
- Lighting and temperature control

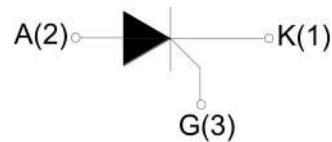
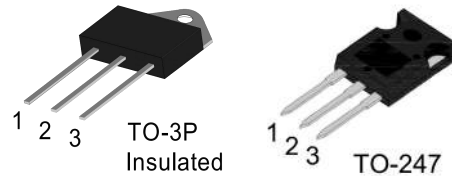

## Parameters Summary

**VD/VR:1200/1600V**

**IT(RMS):55A**

**IGT :60mA**

ABSOLUTE MAXIMUM RATINGS			
Parameter	Symbol	Value	Unit
Storage junction temperature range	Tstg	-40 ~150	°C
Operating junction temperature range	Tj	-40~125	°C
Repetitive peak off-state voltage (T =25°C)	V <sub>DRM</sub>	1200/1600	V
Repetitive peak reverse voltage (T =25°C)	V <sub>RRM</sub>	1200/1600	V
Non repetitive surge peak Off-state voltage	V <sub>DSM</sub>	V <sub>DRM</sub> +100	V
Non repetitive peak reverse voltage	V <sub>RSM</sub>	V <sub>RRM</sub> +100	V
RMS on-state current	TO-3PIns.(TC=80°C)	I <sub>T(RMS)</sub>	55
	TO-247(TC=85°C)		
Non repetitive surge peak on-state current	I <sub>TSM</sub>	550	A
Average on-state current (180° conduction angle)	I <sub>T(AV)</sub>	35	A
I <sup>2</sup> t value for fusing (tp=10ms)	I <sup>2</sup> t	1500	A <sup>2</sup> S
Critical rate of rise of on-state current (I =2×IGT, tr ≤ 100 ns)	di/dt	150	A/μS
Peak gate current	I <sub>GM</sub>	5	A
Average gate power dissipation	P <sub>G(AV)</sub>	2	W

Thermal Resistances					
Symbol	Parameter		Value	Unit	
Rth(j-c)	Junction to case (DC)		TO-3P	0.65	°C/W
			TO-247	0.60	

ELECTRICAL CHARACTERISTICS (T=25°C unless otherwise specified)					
Symbol	Test Condition		Value	Unit	
$I_{GT}$	V = 12V R = 140Ω		MAX.	60	mA
$V_{GT}$			MAX.	1.3	V
$V_{GD}$	VD = VDRM Tj = 125°C		MIN.	0.2	V
$I_L$	$I_G = 1.2 I_{GT}$		MAX.	250	mA
$I_H$	IT = 50mA		MAX.	200	mA
dV/dt	VD = 2/3 VDRM Gate Open Tj = 125°C		MIN.	1000	V/μs

STATIC CHARACTERISTICS					
Symbol	Parameter		Value(MAX. )	Unit	
$V_{TM}$	ITM = 80A tp = 380μs	Tj = 25°C	1.8	V	
$I_{DRM}$	VD = VDRM VR = VRRM		Tj = 25°C	20	μA
$I_{RRM}$			Tj = 125°C	8	mA

### Ordering Information Scheme

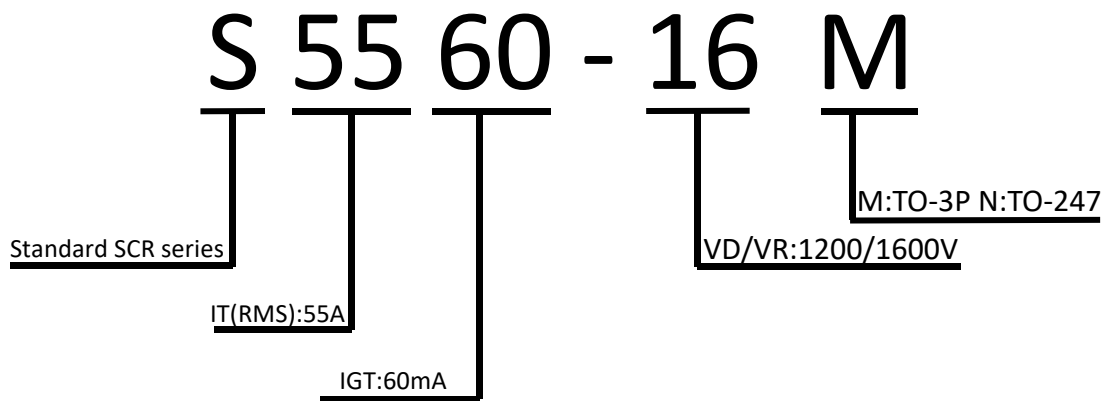

## TO-247 Package Mechanical Data

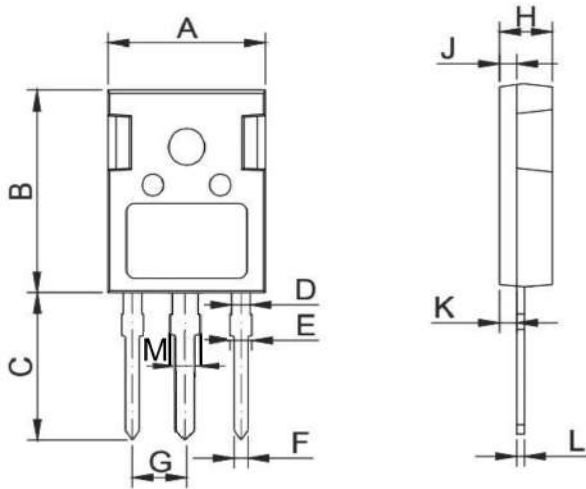

Ref.	Dimensions					
	Millimeters			Inches		
	Min.	Typ.	Max.	Min.	Typ.	Max.
A	15.50	15.80	16.10	0.610	0.622	0.634
B	20.80	21.00	22.20	0.819	0.828	0.874
C	19.70	20.00	20.30	0.776	0.787	0.799
D	1.80	2.00	2.20	0.071	0.079	0.087
E	1.90	2.10	2.30	0.075	0.083	0.097
F	1.00	1.20	1.40	0.039	0.047	0.055
G		5.44			0.214	
H	4.80	5.00	5.20	0.189	0.197	0.205
J	1.90	2.00	2.10	0.075	0.079	0.083
K	2.20	2.35	0.50	0.087	0.093	0.098
L	0.41	0.60	0.79	0.016	0.024	0.098
M	2.90	3.10	3.30	0.114	0.122	0.129

## TO-3P Package Mechanical Data

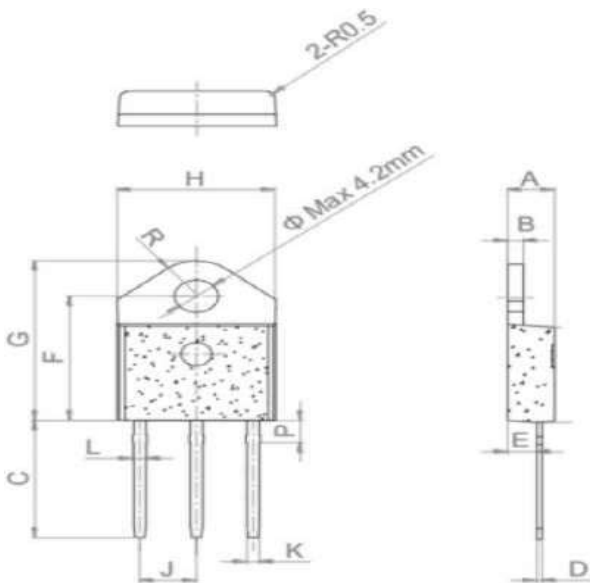

Ref.	Dimensions					
	Millimeters			Inches		
	Min.	Typ.	Max.	Min.	Typ.	Max.
A	4.40		4.60	0.173		0.181
B	1.40		1.60	0.055		0.062
C	15.48		15.88	0.609		0.625
D	0.50		0.70	0.019		0.027
E	2.70		2.90	0.106		0.114
F	15.92		16.32	0.626		0.642
G	20.27		20.67	0.798		0.813
H	15.15		15.35	0.590		0.604
J		5.45			0.214	0.216
K	1.10		1.30	0.043		0.051
L	1.15		1.35	0.045		0.053
P	2.68		3.08	0.105		0.121
R		4.20			0.165	

FIG.1 Maximum power dissipation versus on-state current

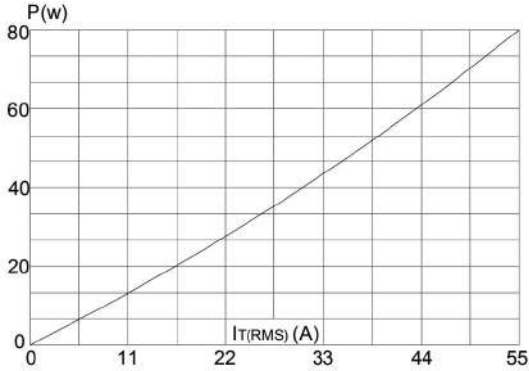

FIG.2: on-state current versus case temperature

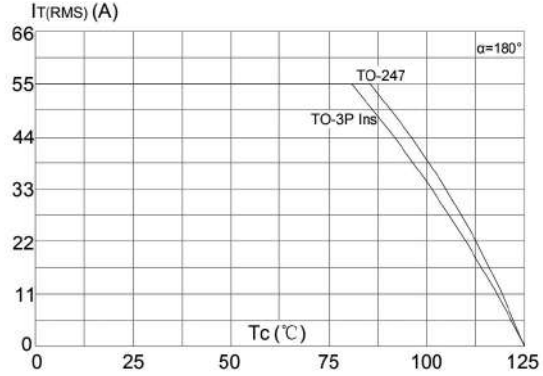

FIG.3: Surge peak on-state current versus number of cycles

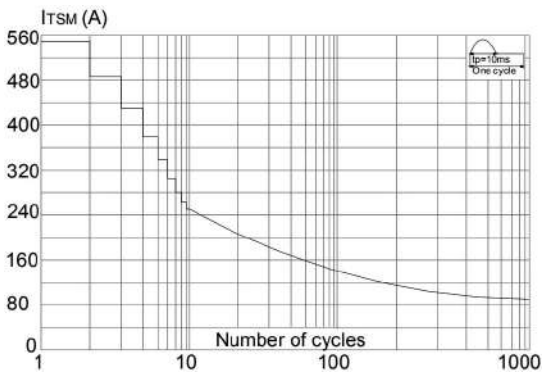

FIG.4: On-state characteristics (maximum values)

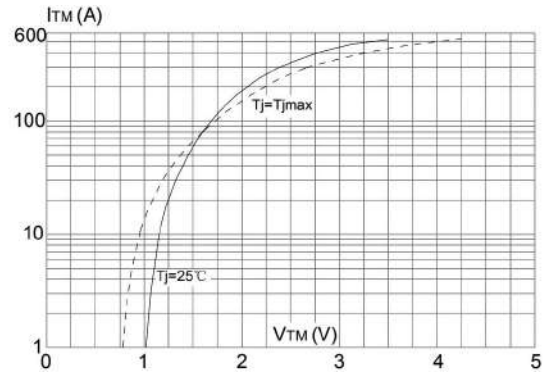

FIG.5: Non-repetitive surge peak on-state current for a sinusoidal pulse with width  $t_p < 10ms$ , and corresponding value of  $I_2 t$

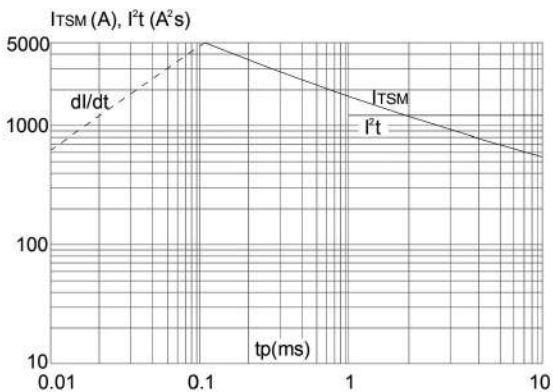

FIG.6: Relative variations of gate trigger current holding current and latching current versus junction temperature

