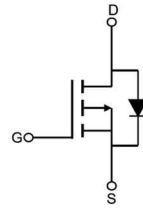


# TP4435C

## P-Channel Enhancement Mosfet

### Feature

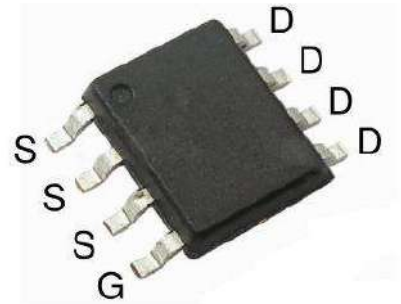
- -30V, -10A  
 $R_{DS(ON)} < 23m\Omega @ V_{GS} = -10V$   
 $R_{DS(ON)} < 34m\Omega @ V_{GS} = -4.5V$
- Trench DMOS Power MOSFET
- Fast Switching
- Exceptional on-resistance and maximum DC current capability



Schematic diagram

### Application

- DC/DC Converter
- Load Switch for Portable Devices
- Battery Switch



SOP-8

### Package Marking and Ordering Information

Device Marking	Device	Device Package	Reel Size	Tape width	Quantity (PCS)
4435	TP4435C	SOP-8	13 inch	-	4000

### ABSOLUTE MAXIMUM RATINGS ( $T_a = 25^\circ C$ unless otherwise noted)

Parameter	Symbol	Value	Unit
Drain-Source Voltage	$V_{DS}$	-30	V
Gate-Source Voltage	$V_{GS}$	$\pm 20$	V
Continuous Drain Current ( $T_a = 25^\circ C$ )	$I_D$	-10	A
Continuous Drain Current ( $T_a = 100^\circ C$ )	$I_D$	-7	A
Pulsed Drain Current <sup>(1)</sup>	$I_{DM}$	-40	A
Singel Pulsed Avalanche Energy	$E_{AS}$	-	mJ
Power Dissipation	$P_D$	3.7	W
Thermal Resistance from Junction to Ambient	$R_{\theta JA}$	33.8	$^\circ C/W$
Junction Temperature	$T_J$	150	$^\circ C$
Storage Temperature	$T_{STG}$	-55~ +150	$^\circ C$

## MOSFET ELECTRICAL CHARACTERISTICS( $T_a=25^{\circ}\text{C}$ unless otherwise noted)

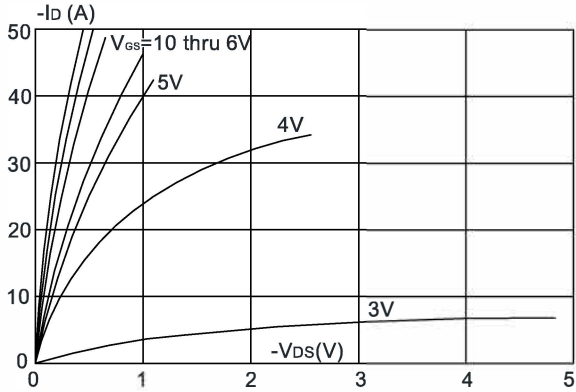
Parameter	Symbol	Test Condition	Min	Type	Max	Unit
<b>Static Characteristics</b>						
Drain-source breakdown voltage	$V_{(BR)DSS}$	$V_{GS} = 0V, I_D = -250\mu A$	-30			V
Zero gate voltage drain current	$I_{DSS}$	$V_{DS} = -30V, V_{GS} = 0V$		-	-1	$\mu A$
Gate-body leakage current	$I_{GSS}$	$V_{GS} = \pm 20V, V_{DS} = 0V$	-	-	$\pm 100$	nA
Gate threshold voltage <sup>(2)</sup>	$V_{GS(th)}$	$V_{DS} = V_{GS}, I_D = -250\mu A$	-1	-1.5	-2.5	V
Drain-source on-resistance <sup>(2)</sup>	$R_{DS(on)}$	$V_{GS} = -10V, I_D = -10A$		16	23	m $\Omega$
		$V_{GS} = -4.5V, I_D = -10A$	-	25	34	
<b>Dynamic characteristics</b>						
Input Capacitance	$C_{iss}$			1550		
Output Capacitance	$C_{oss}$	$V_{DS} = -15V, V_{GS} = 0V, f = 1MHz$	-	327	-	pF
Reverse Transfer Capacitance	$C_{rss}$		-	278	-	
<b>Switching characteristics</b>						
Turn-on delay time	$t_{d(on)}$			14		
Turn-on rise time	$t_r$	$V_{DD} = -15V, I_D = -6A$ $V_{GS} = -10V, R_G = 2.5\Omega$ $V_{DS} = -15V, I_D = -10A,$ $V_{GS} = -10V$	-	20	-	ns
Turn-off delay time	$t_{d(off)}$		-	95	-	
Turn-off fall time	$t_f$		-	65	-	
Total Gate Charge	Qg		-	30	-	
Gate-Source Charge	Qgs		-	5.3	-	nC
Gate-Drain Charge	Qgd		-	7.6	-	
<b>Source-Drain Diode characteristics</b>						
Diode Forward voltage <sup>(2)</sup>	$V_{DS}$	$V_{GS} = 0V, I_S = -10A$			-1.2	V
Diode Forward current <sup>(3)</sup>	$I_S$		-	-	-10	A
			-	-		

### Notes:

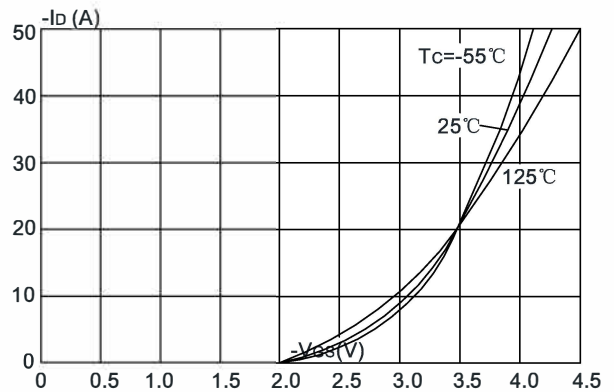
1. Repetitive Rating: pulse width limited by maximum junction temperature
2. Pulse Test: pulse width  $\leq 300\mu s$ , duty cycle  $\leq 2\%$
3. Surface Mounted on FR4 Board,  $t \leq 10$  sec

## Typical Performance Characteristics

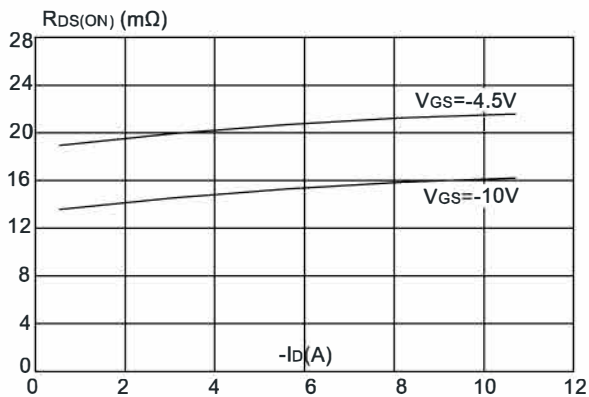
**Figure 1: Output Characteristics**



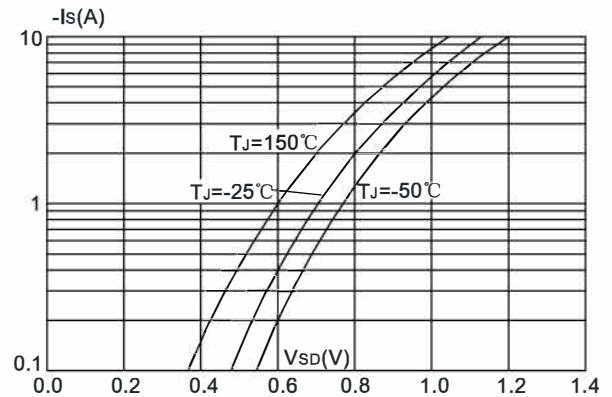
**Figure 2: Typical Transfer Characteristics**



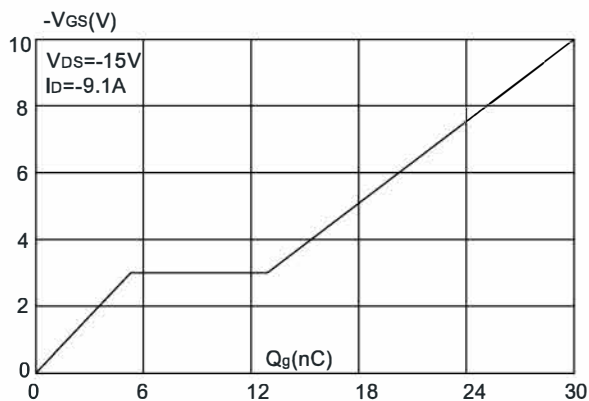
**Figure 3: On-resistance vs. Drain Current**



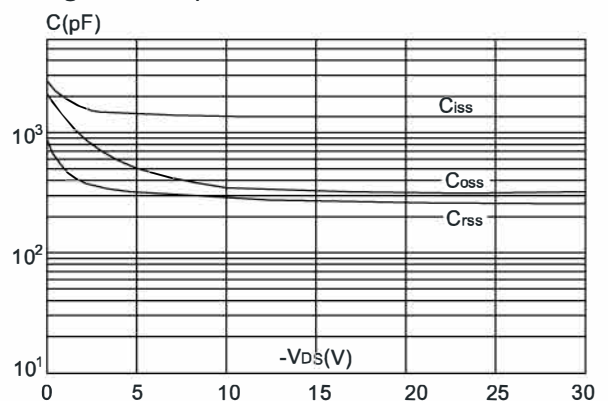
**Figure 4: Body Diode Characteristics**



**Figure 5: Gate Charge Characteristics**

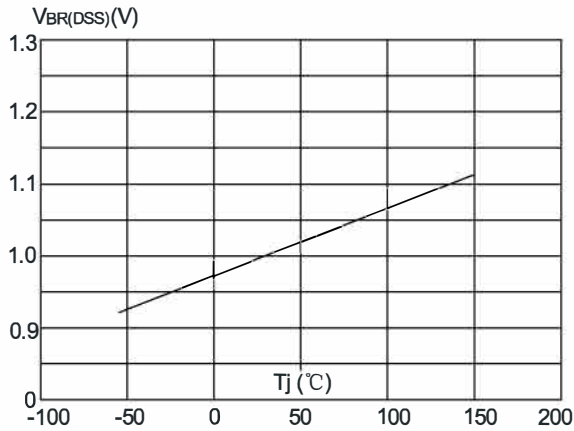


**Figure 6: Capacitance Characteristics**

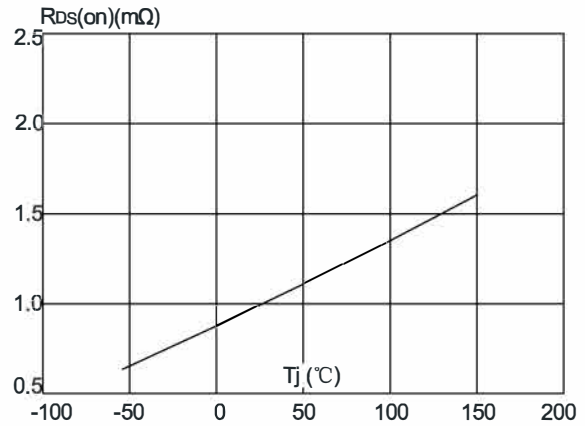


## Typical Performance Characteristics

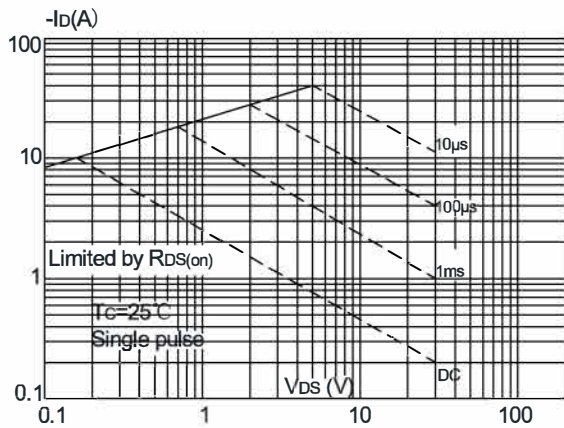
**Figure 7:** Normalized Breakdown Voltage vs. Junction Temperature



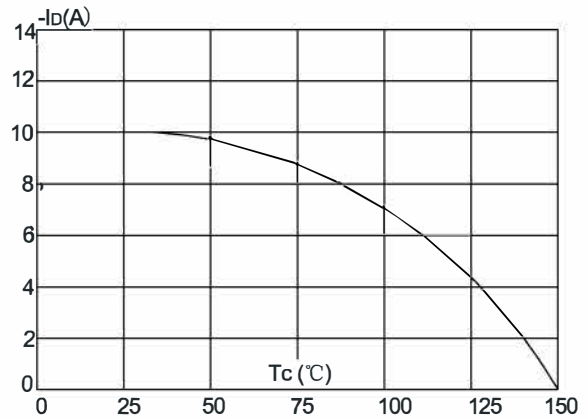
**Figure 8:** Normalized on Resistance vs. Junction Temperature



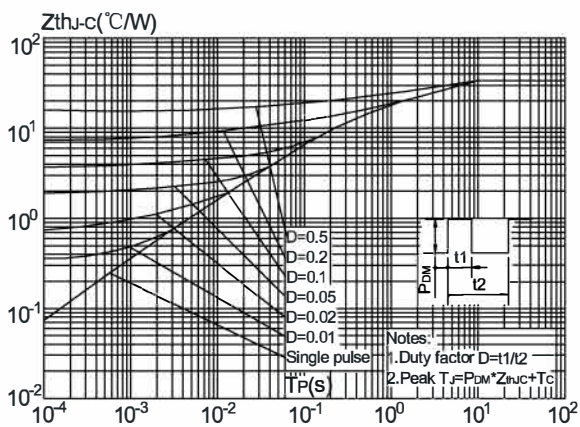
**Figure 9:** Maximum Safe Operating Area



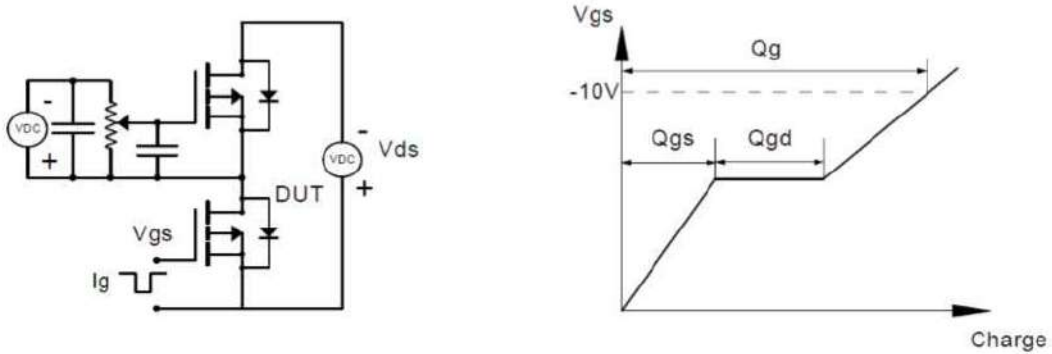
**Figure 10:** Maximum Continuous Drain Current vs. Case Temperature



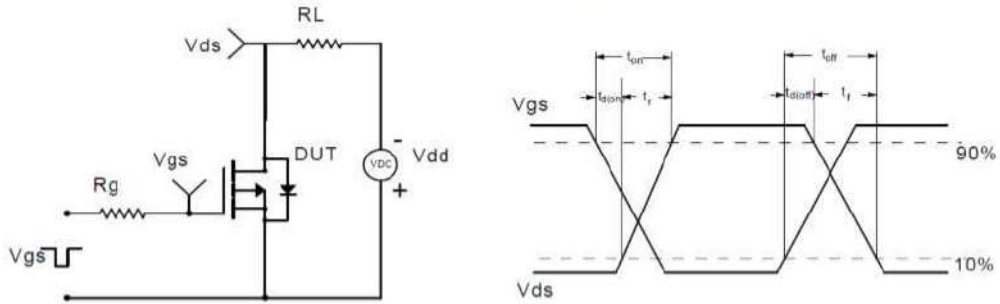
**Figure.11:** Maximum Effective Transient Thermal Impedance, Junction-to-Ambient



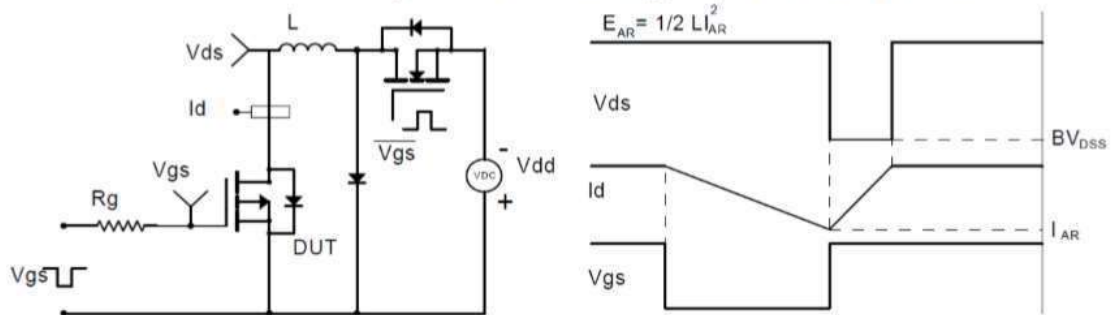
Gate Charge Test Circuit & Waveform



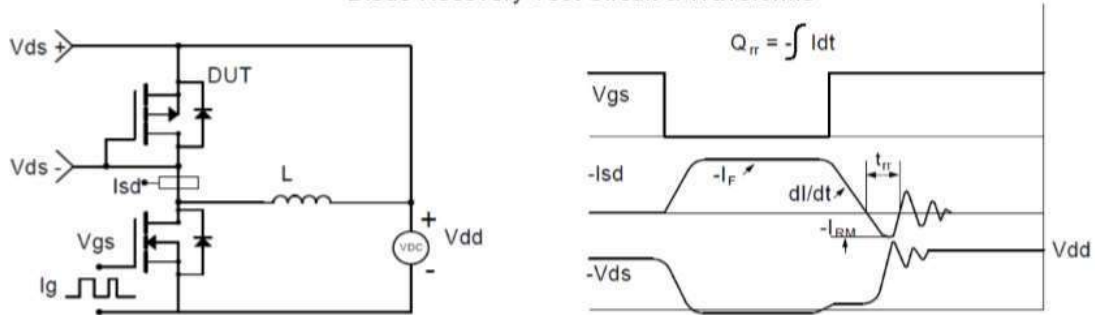
Resistive Switching Test Circuit & Waveforms



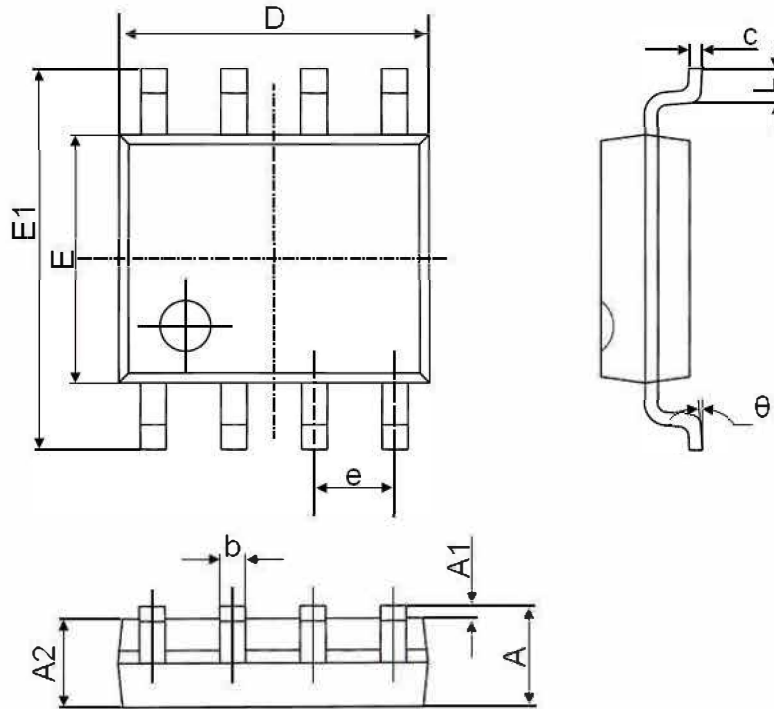
Unclamped Inductive Switching (UIS) Test Circuit & Waveforms



Diode Recovery Test Circuit & Waveforms



## SOP-8 Package Information



Symbol	Dimensions In Millimeters		Dimensions In Inches	
	Min.	Max.	Min.	Max.
A	1.350	1.750	0.053	0.069
A1	0.100	0.250	0.004	0.010
A2	1.350	1.550	0.053	0.061
b	0.330	0.510	0.013	0.020
c	0.170	0.250	0.006	0.010
D	4.700	5.100	0.185	0.200
E	3.800	4.000	0.150	0.157
E1	5.800	6.200	0.228	0.244
e	1.270(BSC)		0.050(BSC)	
L	0.400	1.270	0.016	0.050
θ	0°	8°	0°	8°